

SPECIFICATION

产品规格书

Revision: 1.4

Issued Date: 2022-04-01

Model No.: MMP260-4.2

Description: POWER SUPPLY

PREPARED BY 编写	CHECKED BY 审核	APPROVED BY 批准
谢基	唐植盛	蓝裕民

深圳麦格米特电气股份有限公司

SHENZHEN MEGMEET ELECTRICAL TECHNOLOGY CO., LTD

Add: 5th floor, Block B, Ziguang information harbor, Langshan Road,
Shenzhen, P. R. China

Tel: +86 0755-2660 0500 Fax: +86 0755-8660 0999

E-mail: megmeet@megmeet.com; <http://www.megmeet.com>

Revision History

修订履历

Revision 版本/次	Change Item (修改项次)	Date (修改日期)
1.0	Initial Release (第一版发行)	2014-11-25
1.1	1、增加原理框图 2、更改海拔高度（由3000米更改为5000米）	2014-12-06
1.2	更新安装尺寸图	2015-11-18
1.3	工作温度：低温-40℃-60℃	2018-11-18
1.4	应客户要求，安装尺寸图标注公差	2022-04-01

Content 目录

1. Electrical Specification 电气规格:	4
1.1 Block diagram (原理框图):	4
1.2 Input Electrical Characteristics (输入特性)	5
1.3 Output Electrical Characteristics (输出特性)	5
1.3.1 Output Voltage & Current Regulation (输出电压电流调整率)	5
1.3.2 Input voltage Derating Guideline 输入电压降额曲线	5
1.3.3 Operate temperature rating Guideline 工作温度降额曲线	6
1.3.4 DC Output Ripple & Noise. (输出纹波和噪声)	6
1.3.5 Output Transient Response. (输出动态响应)	7
1.3.6 Hold-Up Time (输出保持时间)	7
1.3.7 DC Output Overshoot During Turn-On & Turn-Off (输出超调)	7
1.3.8 DC output voltage rise time (输出上升时间)	7
1.4 Protection (保护功能)	8
1.4.1 DC Output Over current Protection (输出过流保护)	8
1.4.2 DC Output Short Circuit Protection (输出短路保护)	8
1.4.3 Over voltage Protection (输出过压保护)	8
2. Isolation (绝缘性能)	8
2.1 Insulation Resistance (绝缘阻抗)	8
2.2 Dielectric Strength (绝缘耐压)	8
3. Safety (安全规格)	9
4. EMC (电磁兼容性)	9
4.1 EMI (电磁干扰)	9
4.2 EMS (电磁抗扰)	9
5. Environmental Requirement (工作环境)	10
5.1 Temperature (环境温度)	10
5.2 Humidity (环境湿度)	10
5.3 Altitude (海拔高度)	10
5.4 Cooling Method (冷却方式)	10
5.5 Vibration (振动耐受)	10
5.6 Shock (冲击耐受)	10
6. Dimension (物理尺寸)	10
7. Weight (重量)	10
8 Pin Connection (连接器脚位定义)	11
9. Picture(实物图片)	11
10. Power Supply Mounting dimension (安装尺寸) 单位 (mm)	11
11. Requirements for Burning in Test. 老化测试要求	12

1. Electrical Specification 电气规格:

1.1 Block diagram (原理框图)

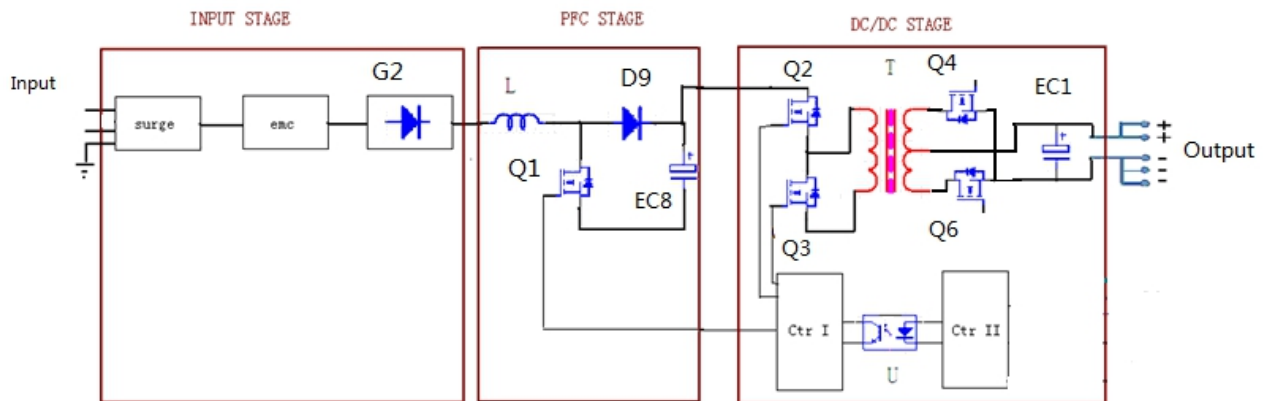

The power supply unit consists of input stage, PFC stage, DC/DC stage, and control circuit. Input stage includes surge protect circuit, EMC circuit, soft-start-up circuit, etc. This circuits help to meet EMC regular of EN55022 etc. DC/DC stage delivers a desired output voltage. Control circuit carries out many functions as OVP, OLP, OTP, loop control.

Main components functions are described as below:

- G2- input rectifier
- EC8- Input Capacitor
- Q1- PFC Mosfet
- D9- PFC Output Diode
- EC8- PFC Output Capacitor
- Q2&Q3- DC/DC Mosfet
- Q4&Q6- DC/DC Output Synchronic-Rectifiers
- EC1- Output Capacitor
- U- Isolated Opt couple for feedback control

1.2 Input Electrical Characteristics (输入特性)

Table 1

Input voltage range 输入电压	90Vac to 264Vac
Normal voltage range 标称输入	100Vac to 240Vac
Frequency range 频率范围	47Hz-63Hz
Max input ac current 最大输入电流	3.5Amax at full load condition
Inrush current (cold state) 浪涌电流	80A _{typ} peak@220Vac
Efficiency (full load) 效率	87%min@220Vac
Leakage Current 泄漏电流	Less Than 3.5 mA, @ 240Vac input
Normal output power 额定功率	210W
Input Fuse 输入保险	T5AH/250Vac
Power Factor 功率因素	>0.95 @ full Load 220Vac input

1.3 Output Electrical Characteristics (输出特性)

1.3.1 Output Voltage & Current Regulation (输出电压电流调整率)

Table 2

Output Voltage 输出电压	Regulation 调整率	Min. current 最小电流	Rated current 额定电流
+4.2V	±5%	0A	50A

Note:* The testing of peak current shall be performed under the peak current pulse width within 100ms conditions.

峰值电流的测试条件是脉宽小于 100 毫秒。

1.3.2 Input voltage Derating Guidline 输入电压降额曲线

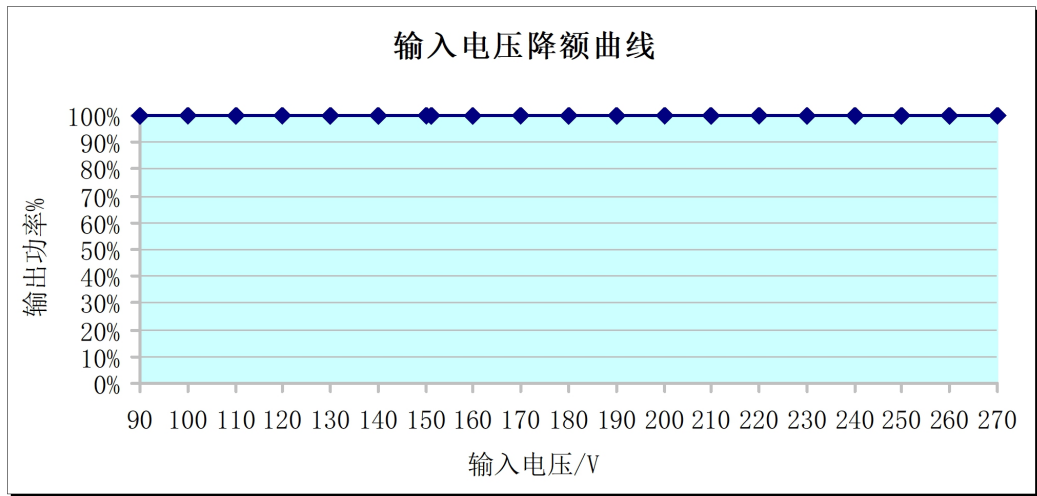

备注：测试时电源模块机壳需要紧贴散热板，散热板具体尺寸见图一

1.3.3 Operate temperature rating Guidline 工作温度降额曲线

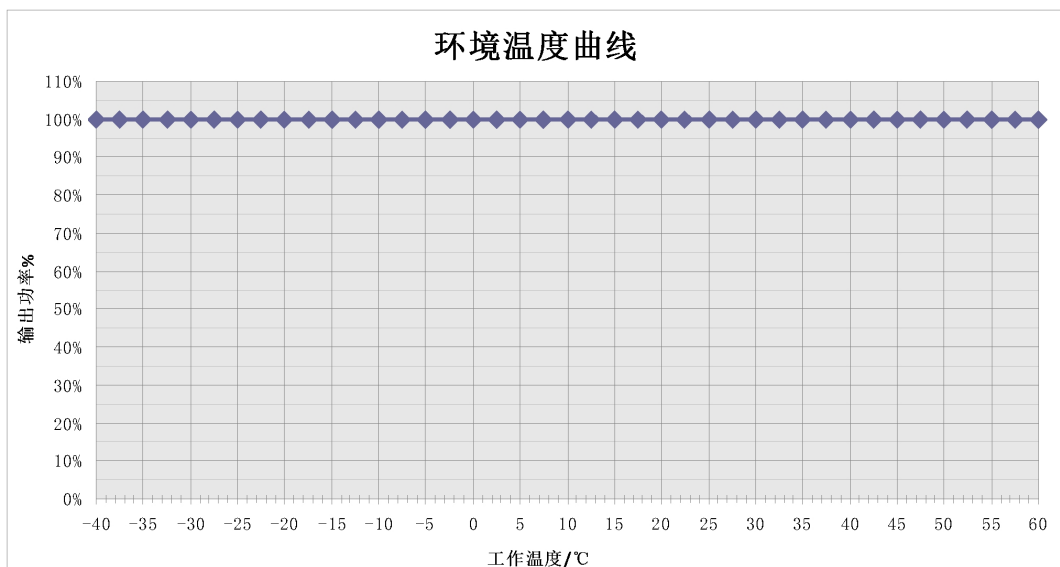

1.3.4 DC Output Ripple & Noise. (输出纹波和噪声)

Table 5

Output Voltage	Ripple & Noise (Max.)
+4.2V	200mVp-p@ 25°C
	300mVp-p@-40°C (满载工作半小时后测试)

Note: 1) Ripple & Noise test: Ripple & Noise bandwidth is set to 20MHz.
纹波和噪声测试：纹波和噪音带宽设置在 20 兆赫兹。

2) Use a 0.1uF ceramic capacitor in parallel with a 10uF electrolytic capacitor at output connector terminals for ripple & noise measurements.

输出端并联一个 0.1uF 的陶瓷电容和一个 10uF 的电解电容来测试纹波和噪声。

1.3.5 Output Transient Response. (输出动态响应)

Table 6. Test condition.测试条件

Voltage Tolerance Limit	Slew Rate	Load Change
+4.2V $\leq\pm 5\%$	1A/uS	25% to 50% load and 50% to 75% load
+4.2V $\leq\pm 10\%$	1A/uS	25% to 100% load

Note: Load change repetition rate: 100Hz to 10kHz . 跳变负载频率 100~10kHz.

1.3.6 Hold-Up Time (输出保持时间)

Table 5

Output Voltage	100Vac input	220Vac input
+4.2V	≥ 10 mS	≥ 10 mS

Note: All of dc output at full load. 所有输出带满载。

1.3.7 DC Output Overshoot During Turn-On & Turn-Off (输出超调)

Table 8

Output Channel	Output(V)	Overshoot voltage(V)超调电压	
		Turn-on 开机	Turn-off 关机
+4.2V	+4.2V	$\leq 10\%$	$\leq 10\%$

Note: All of dc output current from Min. to Max.
测试时负载范围：最小到最大。

1.3.8 DC output voltage rise time (输出上升时间)

Table 9

Output Voltage	120Vac input &Full Load	220Vac input &Full Load
+4.2Vdc	≤ 100 mS	≤ 100 mS

Note: The rise time measured is when the output voltages rise from 10% to 90% of specified output voltage Vout observed on the channel waveform.
上升时间为输出电压从 10%上升到 90%的时间。

1.3.9 Power on delay time (开机输出延迟时间)

Table 10

Output Voltage	220Vac input @ 25°C	220Vac input @ -25°C
+4.2V	≤3S	≤5S

Note: The Power delay time measured is when AC power on to 90% of specified output voltage observed on the channel waveform.

开机延迟时间为 AC 上电到输出电压 90%的时间。

1.4 Protection (保护功能)

1.4.1 DC Output Over current Protection (输出过流保护)

Table 9

Output Voltage	Over Current	Comments
+4.2V	>55A Typ.	Turn off (可恢复)

1.4.2 DC Output Short Circuit Protection (输出短路保护)

Table 11

Output Voltage	Comments
+4.2V	Turn off (可长期短路, 可自恢复)

1.4.3 Over voltage Protection (输出过压保护)

Table 13

Output Voltage	Comments
+4.2Vdc	6.5V Max. (可恢复)

2. Isolation (绝缘性能)

2.1 Insulation Resistance (绝缘阻抗)

Table 13

Input To Output	DC500V 10 MΩ min. (at room temperature)
Input To FG	DC500V 10 MΩ min. (at room temperature)
Output To FG	DC500V 10 MΩ min. (at room temperature)

2.2 Dielectric Strength (绝缘耐压)

Table 14

Input To Output	3000Vac	1minute ≤10mA
Input To FG	1500Vac	1minute ≤10mA
Output to FG	500Vdc	1minute ≤10mA

Notes: Input line (L&N) should be shorted, and all output should be Shorted.

电路如有防雷器件，进行耐压测试时需断开放电气隙管后进行如下操作：

输入线需要短接（L&N）在一起，所有的输出线需要短接在一起。

输入对输出： 输入短接线 TO 输出短接线测试

输入对 FG： 输入短接线 TO FG

输出对 FG： 输出短接线 TO FG

3. Safety （安全规格）

The power supply shall comply with the following criterion:

电源安全性满足下列标准：

- 1) UL60950/IEC60950/EN60950
- 2) GB4943

4. EMC （电磁兼容性）

4.1 EMI （电磁干扰）

The power supply shall comply with the following criterion:

电源电磁干扰满足下列标准：

1) Conduction Emission : （传导干扰度）

*EN55022, CLASS A

*FCC PART15 CLASS A

2) Radiated Emission : （辐射干扰度）

*EN55022, CLASS A

*FCC PART15 CLASS A

Note: Megmeet can work together with customer to modify the power and the system to meet above criterion.

如果客户需要，可以配合在客户整机上进行更改，达到标准

4.2 EMS （电磁抗扰）

The power supply shall comply with the following criterion:

电源电磁抗扰满足下列标准：

1) ESD （静电抗扰度）

*GB17626.2/IEC61000-4-2 Level 3 判据： A

2) EFT （脉冲群抗扰度）

*GB17626.4/IEC61000-4-4 Level 3 判据： A

3) SURGE （浪涌）

- *GB17626.5/IEC61000-4-5 Level 3 判据: B
- 4) DIP (电压跌落)
*GB17626.11/IEC61000-4-11 判据: C
电源 DIP 电压跌落要求表

跌落至	跌落时间	性能判据
0%Ut	10ms	B
70%Ut	500ms	C
40%Ut	200ms	C
0%Ut	5000ms	C

- 5) Lighting (雷击) NOT APPLICABLE /不适用

5. Environmental Requirement (工作环境)

5.1 Temperature (环境温度)

- * Operating 工作温度: -40°C to $+60^{\circ}\text{C}$.
Note: the power can power on and work @ -40°C
 -40°C 低温能够开机工作, 电源正常工作时没有啸叫声
- * Storage 存储温度: -40°C to $+85^{\circ}\text{C}$.

5.2 Humidity (环境湿度)

- * Operating 工作: From 10% to 90% relative humidity (non-condensing).
* Storage 存储: From 5 to 95% relative humidity (non-condensing).

5.3 Altitude (海拔高度)

- * Operating: -60 to 5000m
* Storage: up to 5000 m

5.4 Cooling Method (冷却方式)

- * 自然冷却

5.5 Vibration (振动耐受)

- * 10-55Hz, 19.6m/s^2 (2G), 20minutes each along X, Y and Z axis.

5.6 Shock (冲击耐受)

- * 49m/s^2 (5G), 11ms, once each X, Y and Z axis.

6. Dimension (物理尺寸)

- *190mm X70 mm X 30mm(长 L *宽 W * 高 H)

7. Weight (重量)

520g

8 Pin Connection (连接器脚位定义)

输入:

Table 15

序号	引脚定义
PIN1	LINE
PIN2	NETURAL
PIN3	EARTH

输出:

Table 16

序号	引脚定义
PIN1	Vo-
PIN2	Vo-
PIN3	Vo+
PIN4	Vo+

9. Picture(实物图片)



10. Power Supply Mounting dimension (安装尺寸) 单位 (mm)

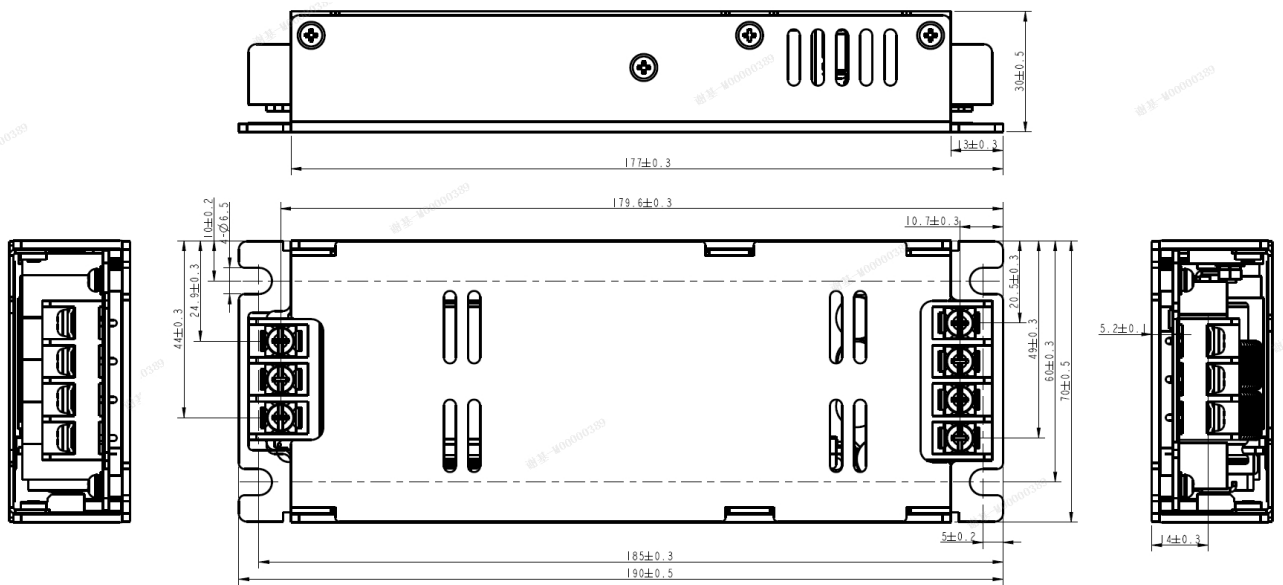

11. Requirements for Burning in Test. 老化测试要求

We recommend that the Power Supply should be mounted tightly with the heatsink described as the following heatsink drawing while the products burn in at 40°C and 220Vac input. 在环境温度 40°C 下，不加湿，电源输入 220V，带满负载，机壳底面紧贴散热板（建议散热板尺寸见图 1 所示，单位 mm），加电老化。（本规格书中指标，是在建议环境下测试的结果）

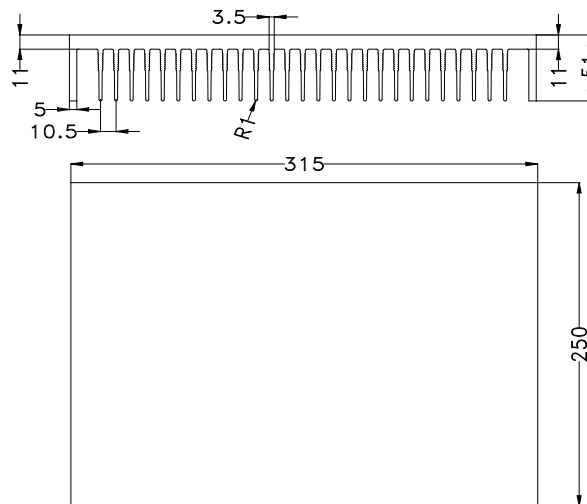

图一 Scheme for Heatsink 散热板尺寸图